

# SPANN-TWIST: LIGHTWEIGHT 3D-PRINTED CHAIN TENSIONER MADE OF HIGH-PERFORMANCE PLASTIC

## PRODUCT FEATURES



### CURVED LEVER MOTION

Clamping stroke up to 60 mm possible

### EASY TO INSTALL

Multi-hole plate for flexible mounting and compact design;  
CAD data available

### DESIGN FLEXIBILITY

Complex geometries for tight installation spaces, without  
tooling costs

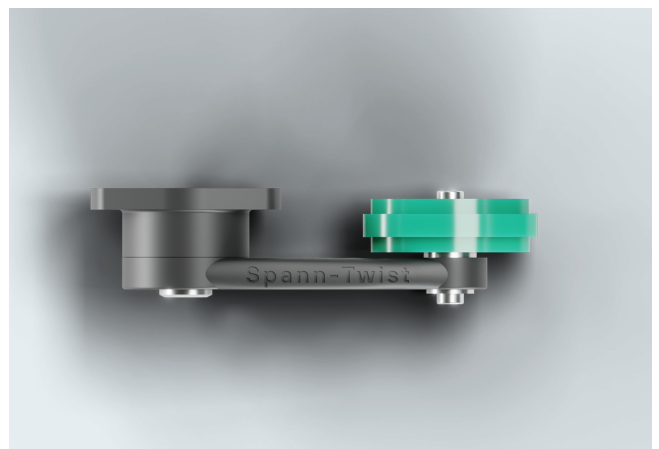

**TECHNICAL INFORMATION**

SPANN-TWIST: Lightweight 3D-printed chain tensioner, made of high-performance plastic

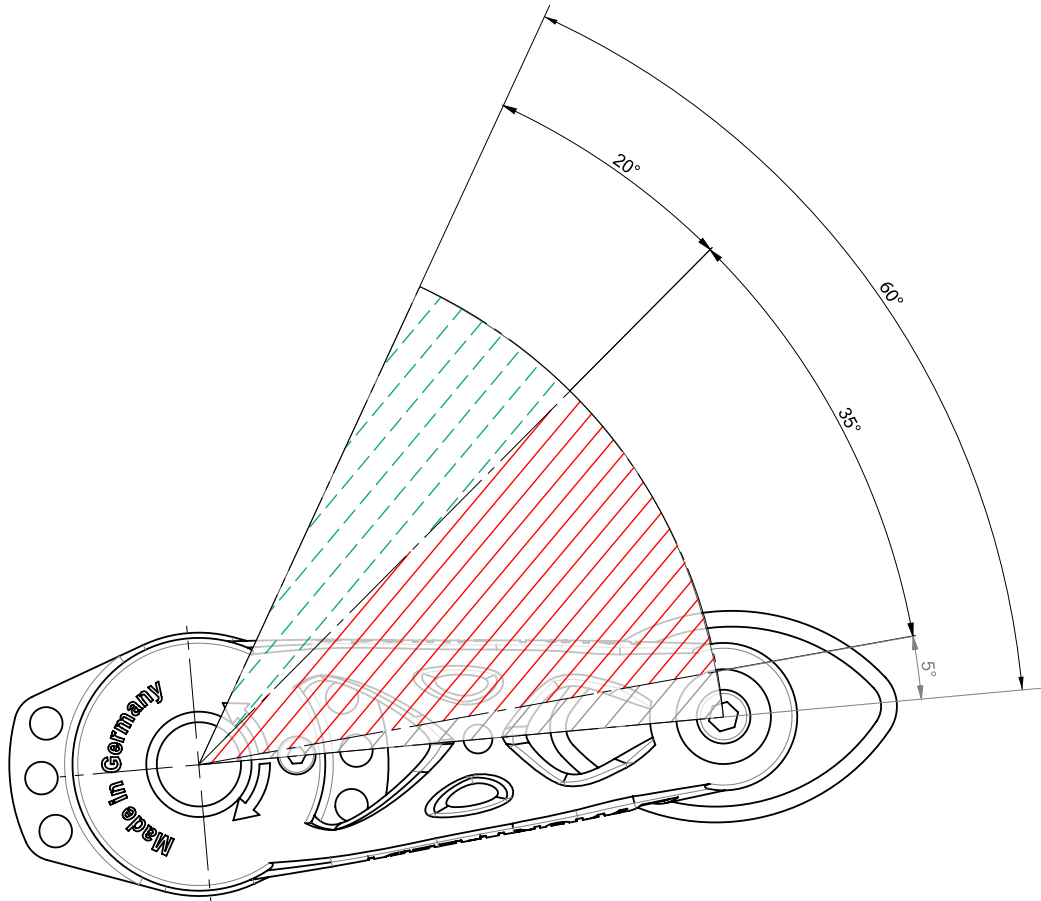

Range	Degree	Travel	Clamping Force (Light)
Red zone	40° - 60°	8 mm	25 - 0 N
Green zone	5° - 40°	50 mm	50 - 25 N
Preload	0° - 5°	20 mm	65 - 50 N

## INSTALLATION INSTRUCTIONS

### PREPARATION

The Spann-Twist is delivered in a **locked and secured state**.

The **locking screw (①)** is removed and the chain tensioner is activated only immediately before commissioning.

Installation must be performed **exclusively by qualified personnel**.



### INSTALLATION STEPS

#### 1. Positioning:

Position and align the **Spann-Twist in the locked position** at the designated location on the machine.

#### 2. Mounting:

Drill mounting holes for **M6 screws** and secure the clamping twist properly.

*An adapter plate is required for chain sizes 10B-2 and larger.*

#### 3. Release the lock:

Do not remove the locking screw (①) until installation is complete.

This releases the lock and activates the chain tensioner.  
*(Note: See illustration – position and orientation of the locking screw)*

#### 4. Inspection:

Check that the tensioning range (**max. 40° / 60 mm**) is fully accessible. Ensure that the chain is properly seated against the guide rail.

## FEATURES AND VALUES

Features	Values
Pitch	max. 40° / 60 mm
Tension	Light: max. 42 N Heavy: max. 55 N (available upon request)
Material	Arm & Housing: PA2200 (3D-printed) Slide profile: ORIGINAL S@ green Torsion spring: V2A
Temperature range	Standard version: -40 °C to +60 °C Custom versions available upon request: up to +200 °C
Compatible chains	DIN 8187: 06B-1 to 12B-1 Duplex and triplex upon request DIN 8188: ASA-35 to ASA-60
Maximum chain speed	max. 1 m/s

## CUSTOM MODELS

In addition to our standard versions, we offer the possibility to implement **customer-specific special solutions**.

Working in close coordination with the customer, we can individually adapt and engineer the **geometry, tensioning characteristics, materials, or operating parameters**.

Please feel free to contact us for further information.

## SICHERHEITSHINWEISE UND WARTUNG



### SAFETY INSTRUCTIONS

- Do not attempt to open the housing – Parts are under spring pressure
- Disconnect the machine from the power supply before installation
- Secure the Spann-Twist during maintenance (use the locking mechanism)



### MAINTENANCE

- Perform regular visual inspections of the sliding profile.
- To extend its service life, the sliding profile can be rotated.
- If there is significant wear, the sliding profile must **be replaced**.